

DECKMA GmbH

Decksmaschinen und Automation Vertriebs GmbH

Fon: +49 (0)4105 - 65 60-0 · Fax: +49 (0)4105 - 65 60-25 · Web: www.deckma-gmbh.de · E-Mail: info@deckma-gmbh.de

Elektronische Hupe / Electronic Horn

H110T

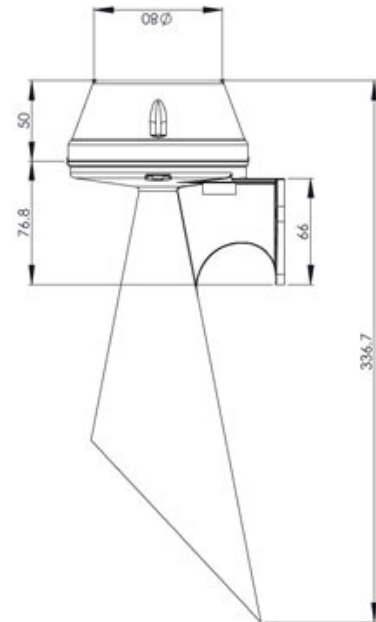
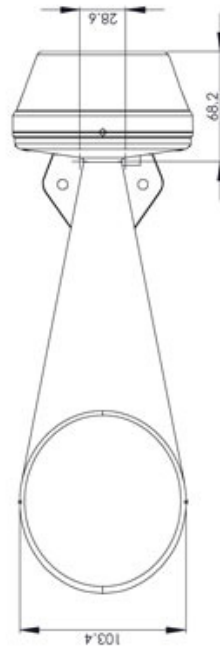

Materialien	Gehäuse aus ABS Kunststoff, selbst verlöschend.	Materials	Body of ABS plastic. Self extinguishing.
Montage	Befestigung mit 2 Schrauben	Mounting	2 screws
Kabeleinführung	1 Kabeleinführung	Cable entry	1 gland knockout
Schutzart	IP65	Protection class	IP65
Klang	3 verschiedene Signal-Töne sind möglich	Sound	3 different signal tones are possible
Gewicht	0,340 kg	Weight	0,340 kg
Lautstärke	110 dB(A)	Volume	110dB(A)
Stromaufnahme	0,018A oder 0,105A	Current	0,018A or 0,105A
Spannung	230V AC oder 10-30V DC	Voltage	230V AC or 10-30V DC
Type	Merkmale	Features	Best. Nr. / Order No.
H110T30G	10-30V DC, IP65	10-30V DC, IP65	004-034
H110T230G	40V- 230V AC, IP65	40V-230V AC, IP65	004-035