

Fire Alarm System FMS3000 Installation Instructions

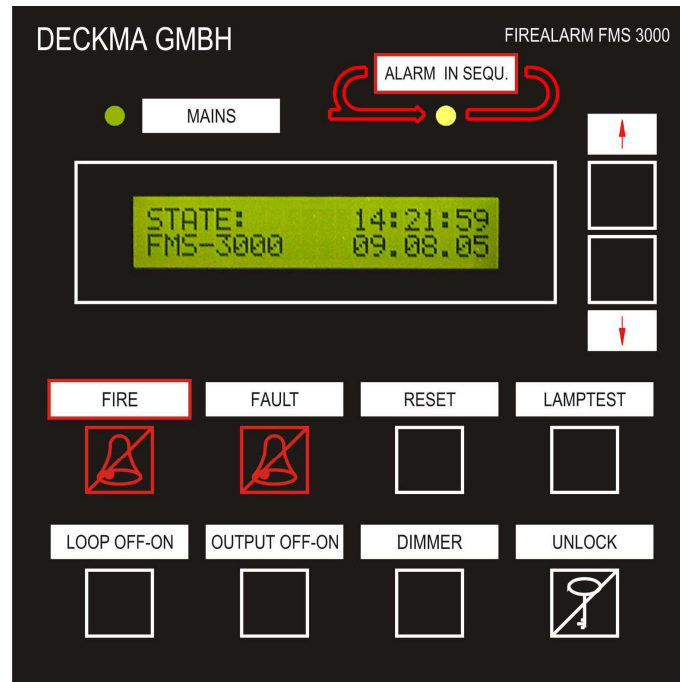

Version history

Version	Date	Author	Checked	Note
0.1	16/09/13	JB	TK	Produced based on the old operating instructions

Checked by

ES Elektronik Service; Jan Broockmann
Name – company

23/09/2013
Date

Approved by

Thomas Kruse DECKMA-GMBH
Name – company

23/09/2013
Datum

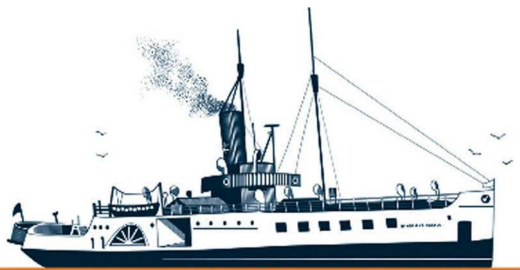

DECKMA GmbH

Decksmaschinen und Automation Vertriebs GmbH

Fon: +49 (0)4105 - 65 60-0 · Fax: +49 (0)4105 - 65 60-25 · Web: www.deckma-gmbh.de · E-Mail: info@deckma-gmbh.de

Technical documentation

201309IA

FMS3000

Index

1. Cabling requirements	3
2. Fire detectors	5
2.1. Sensor and base	5
2.2. Connection of different fire detector types	5
2.3. Guideline for the installation of sensors and bases or fire detectors	7
2.4. Testing the fire detectors	7
3. Commissioning	8
3.1. General	8
3.2. Outputs	8
3.3. Setting the BUS address	9
3.4. Termination resistors	9
3.5. Use of the modules/components	9
3.6. Organisation of the software versions	10
3.7. Sequence of on-board commissioning	10
4. Maintenance	10
4.1. Checking the fire detectors	10
4.2. Checking and changing the accumulator	10
5. Installation	11
5.1. Console installation	11
5.2. Switch cabinet installation	11
6. Configuration	13

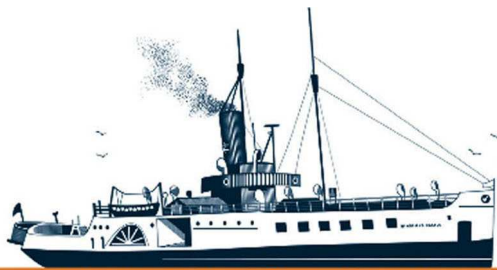

General

The FMS3000 consists of several modules in separate housings. The individual modules are connected to each other through an internal BUS (Binary Unit System) and a common supply voltage (24V DC). All modules, with the exception of the main panel, are intended for mounting on a support rail and are normally installed together in a metal switch cabinet. The main panel (HT) is constructed as a front panel built-in device. The FMS3000 can either be wall mounted or mounted in a console.

When a fire detector detects a fire, then the fire loop module (FM) recognises the event. The main module (BUS Master) cyclically queries the status of all modules. In the course of this, it receives the fire alarm from the fire loop module (FM). Independent of the configuration, the main module transmits to the output module which outputs it should connect. In addition, it transmits the fire alarm to the VDR module and printer module (if present). VDR and printer module output the fire alarm through a VDR output or through the printer. In addition, the main module informs the main panel (HT) about the fire alarm, and it then warns the user acoustically and optically of a fire.

1. Cabling requirements

For safe operation of the entire system, the following cables are recommended:

Plug	Module	Cable type	Wires - diameter
POWER Main (JN0-M)	power supply	unshielded cable	Min. 3 x 1.5mm ²
POWER Emergency (JN0-E)	power supply	unshielded cable	Min. 3 x 1.5mm ²
24V OUT (JN1)	power supply	unshielded cable	Min. 2 x 1.5mm ²
24V IN/AKKU (JN1)	main module	unshielded cable	Min. 2 x 1.5mm ² (power supply); Min 2 x 1.5mm ² (accumulator)
MONITORING (JN2)	power supply/main module	unshielded cable	Min. 6 x 0.75mm ²
RELAY (JP10)	main module	unshielded cable	Min. 2x0.75mm ²
FMS-BUS (JP1-JP9)	main module/fire loop module (FM)/output module/VDR module/printer module	shielded twisted pair cable	2x2x0.75mm ²
RELAY (JAN,JAP)	fire loop module (FM)	unshielded cable	Min. 2-5 x 0.75mm ² ¹²
LOOP (JLN, JLP)	fire loop module (FM)	unshielded cable	Min. 2-8 x 0.75mm ² ³⁴
RELAY (JR1, JR2)	output module	unshielded cable	Min. 2/8 x 0.75mm ²
24V OUT (JOC1)	output module	unshielded cable	Min. 2/4 x 0.75mm ²
TST IN+24V OUT (JOC2)	output module	unshielded cable	Min. 2/4 x 0.75mm ²
FMS-BUS (JR1)	main panel	shielded twisted pair cable	5 x 2 x 0.75mm ² ⁵

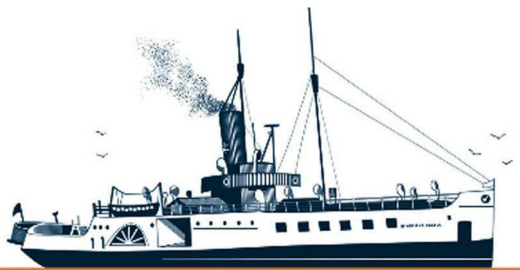

DECKMA GmbH

Decksmaschinen und Automation Vertriebs GmbH

Fon: +49 (0)4105 - 65 60-0 · Fax: +49 (0)4105 - 65 60-25 · Web: www.deckma-gmbh.de · E-Mail: info@deckma-gmbh.de

Technical documentation

201309IA

FMS3000

VDR(RS-458) (JP2)	VDR module	shielded twisted pair cable	2 x 2 x 0.75mm ^{2b}
VDR(RS-232) (JP3)	VDR module	shielded standard serial cable	
PRINTER (JR1)	printer module	shielded standard parallel printer cable	

The recommended cable types are FMGSGO, LMGSGO and MGSGO (Marine) according to VG95218 Part 62.

- ¹ Cross-section according to length of cable and current.
² Number of wires depends on the outputs to be connected.
³ Cross-section depending on the length of the loop.
⁴ Number of wires depends on the outputs to be connected.
⁵ Maximum length: 500m.
⁶ Maximum length: 500m.

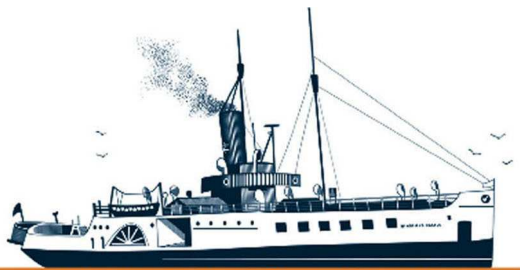

2. Fire detectors

2.1. Sensor and base

Certain fire detectors always consist of a base and a sensor. The conventional sensors SLR-E3, FJ-AE3, DFJ-CE3, DCD-AE3 and DCD-CE3 can all be mounted on the standard base (YBN-R/6). Follow the guideline given below to install and maintain the FMS.

In case these instructions are ignored, correct functioning cannot be guaranteed!

Warning:

The CDX range of sensors cannot be used to prevent fires, but are rather only intended to detect a certain characteristic of a fire.

The sensors DCD-AE3 and DCD-CE3 are used to detect changes of temperature and cannot detect smoke or other phenomena. When installing sensors, check that the location of each individual sensor complies with the applicable regulations and recommendations.

2.2. Connection of different fire detector types

Each fire loop module (FM) has eight conventional loops. After installation, all connections are to be secured with screws to prevent them coming loose due to vibration. The drawing shows a connection plan of various conventional sensor and base types to a fire loop module (FM).

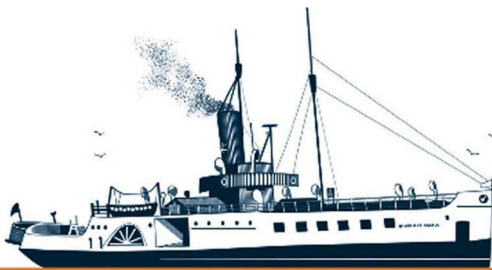

DECKMA GmbH

Decksmaschinen und Automation Vertriebs GmbH

Fon: +49 (0)4105 - 65 60-0 · Fax: +49 (0)4105 - 65 60-25 · Web: www.deckma-gmbh.de · E-Mail: info@deckma-gmbh.de

Technical documentation

201309IA

FMS3000

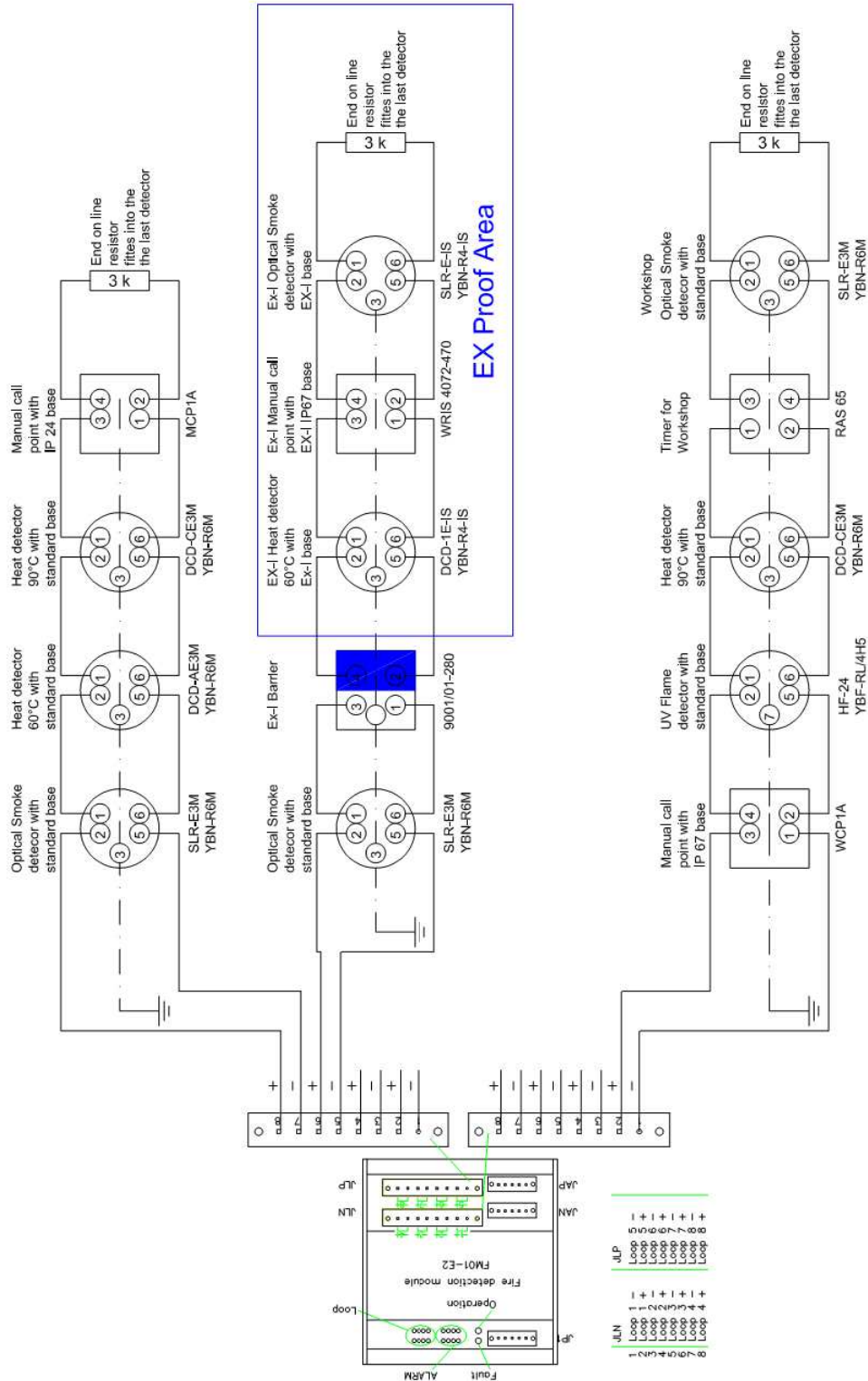

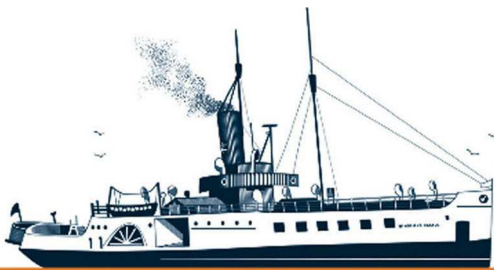

2.3. Guideline for the installation of sensors and bases or fire detectors

- Make sure that fire detectors are installed according to the applicable building regulations and standards.
- Sensor and base combinations should only be installed where:
 - the ambient temperature is between -10°C and $+50^{\circ}\text{C}$.
 - the condensation and humidity values are between 10% and 95% RH – non-condensing (at 40°C).
- Only install fire detectors in suitable environments.
- The following environments should be avoided:
 - Situations, in which there is heavy condensation.
 - Situations, in which aggressive gases are present.
 - Situations, in which dust or steam is present.
 - Situations, in which obstructions could hinder the flow of air to the fire detectors.
 - Areas at risk of explosion.
- Do not use high-voltage testers on the sensor or the base.
- Certain actions can lead to permanent damage to the sensor:
 - Dismantling the housing.
 - Impacts or shocks.

2.4. Testing the fire detectors

- If damage to a fire detector is suspected, it is to be replaced.
- After installation, all fire detectors in the fire alarm system are to be tested to ensure that all function correctly.
- Installation and maintenance should only be carried out by appropriately trained specialist personnel.
- Do not test the function of fire detectors with a flame or open fire.
- Functional tests should be performed with appropriately configured sensor test devices in order to be able to determine correct functioning.
- Maintenance must be carried out after a testing period specified by the regulations of the person responsible for the fire detector system.
- If no such regulations are available, we recommend annual testing. In this case, the following tests are to be included:
 - a visual check for dirt and mechanical damage to the fire detector.
 - a normal function test with smoke detector and/or heat detector test devices.
- Sensors are delivered with a dust protection cover to keep out dirt during installation. This is only to be removed after installation!

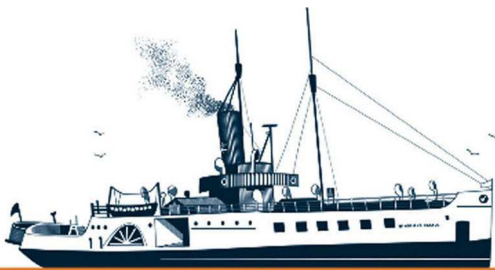

3. Commissioning

The FMS consists of six different modules, which are fixed to a top-hat section rail. More than one example of three modules (main panel (HT), output module and fire loop module (FM)) can be used in an FMS. With these modules, the correct setting of the BUS address and the necessary configuration is important!

3.1. General

The FMS must be connected to the emergency power supply as a "device of secondary operational importance" (see GL/i/1/3 Section 3).

The FMS must be installed on the bridge or in the main fire control station.

One main panel must be installed on the bridge if the FMS is not located on the bridge. An additional main panel is to be installed in the loading control room of ships with a loading control room (see GL/i/1/3 Section 9D)

At least one main panel must be located so that it is accessible for responsible crew members at all times.

3.2. Outputs

The standard assignment of the outputs of the output module must be:

- Machine alarm system (fire alarm, faults)
- General alarm
- VDR
- Fault and common status display

The remaining outputs can be freely configured.

If these outputs are not configured, the MED permit for the FMS immediately becomes invalid.

The relay outputs (output module: JR1, JR2; fire module (FM): JAN, JAP) in the output module and the fire loop module (FM) must be externally monitored for short circuit and cable breakage. For this purpose, a resistor (6k Ω) must be connected in the cable during installation and a resistor (10k Ω) wired parallel to the relay. The current that flows through the circuit must be measured. If the relay is open, less current flows through the resistors R1 and R2. If the relay is closed, a rather higher current flows through resistor R2 and relay1. If the circuit is interrupted, no current flows. In case of a short circuit, a very high current flows.

This protection circuit is intended for a Siemens SPS7n.

Should other resistance values be required, because for example no Siemens SPS7 is available, these can be adapted by the installation company (after discussion with DECKMA) without loss of guarantee claims for the automation. SELCO (USA), for example, works with 82k Ω and 4.7k Ω resistors.

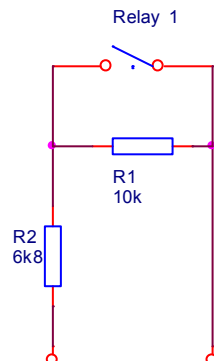
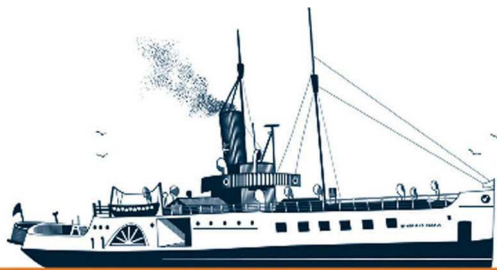

3.3. Setting the BUS address

The main module (NM01) has a rotary switch on the right side of the housing. The BUS address is to be set to 0 in order that the module is the "BUS Master" in the FMS.

The output/fire loop modules (FM) also have a rotary switch on the right side of the housing. The BUS address is to be set to "0" for the first module of this module type. The second module receives the number "1", the third "2" and so on ...

There can also be more than one instance of a main panel (HT) in the FMS. In order to assign a BUS address, a jumper must be inserted over two pins directly into the 15-pole D-SUB connector (FMS-BUS/JR1).

Principal operation	no jumper
Parallel operation 1	jumper between Pin 6 and Pin 14
Parallel operation 2	jumper between Pin 7 and Pin 15

In addition, a termination resistor (120 Ohm) must be inserted in the last main panel in the FMS BUS directly in the D-SUB connector between Pin 12 and Pin 4. Even when only one main panel is being used, a termination resistor is to be inserted!

If more than one identical BUS addresses are present in an FMS BUS, this causes serious communications disturbances. Fault-free operation of the FMS is no longer possible.

3.4. Termination resistors

All fire detector loops must be terminated with a 3K Ω resistor (+/-10%). All "24V OUT" connections (JOC1, JOC2 (output module)) must also be terminated with a 3K Ω resistor.

3.5. Use of the modules/components

Only specifically approved components may be used to assemble a fire alarm system (see standards and regulations).

Recommended is a VDS-approved lead-gel accumulator of type "PBQ 7-12" with a capacity of 7Ah, although all lead-gel accumulators with VDS approval are permissible. The minimum capacity is 1.2Ah, the maximum about 12Ah. If the mains supply fails, the accumulator is loaded with a maximum current of 4A.

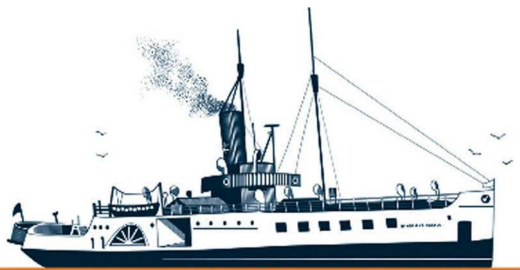

3.6. Organisation of the software versions

The modules of the FMS are each operated with the current software version. The log file "FMS3000_Software_ChangeLog.txt" lists the current status of the software (see document: 1.4 FMS_Software_Beschreibung).

3.7. Sequence of on-board commissioning

- Step 1. Connect all detectors and outputs.
- Step 2. Check all wiring for earth connection, short circuit, polarity and **interference voltages!**
- Step 3. Switch on the FMS and check the overall condition.
- Step 4. Check the fire detector loops.
- Step 5. Check the outputs and additional main panels or other peripheral devices.

4. Maintenance

4.1. Checking fire detectors

The functioning of fire detectors is to be checked at yearly intervals. Dirty and defective detectors are to be replaced immediately. Defective or missing detectors cause a fault report.

4.2. Checking and changing the accumulator

The average lifetime of the accumulator is about 4-5 years at an ambient temperature of 25°C. The accumulators should therefore be replaced as a precaution every 4-5 years. In addition, the main module monitors the accumulator. If the module detects that a fully charged accumulator is weak, then the FMS shows a fault. In this case, the accumulator must be replaced before time!

The average lifetime of the lithium battery (type CR 2032) for the real time clock is about 10 years at an ambient temperature of 25°C. After this period, it is to be replaced.

When changing the lithium battery, care should be taken that the main module is switched off, since changing the battery can cause a short circuit. The data of the real time clock (date, time) must be re-entered after changing the battery.

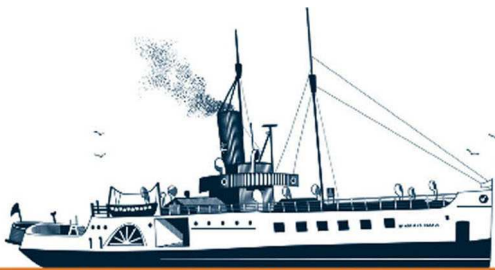

5. Installation

5.1. Console installation

The main panel is installed in the safety console on the bridge and must be well visible.

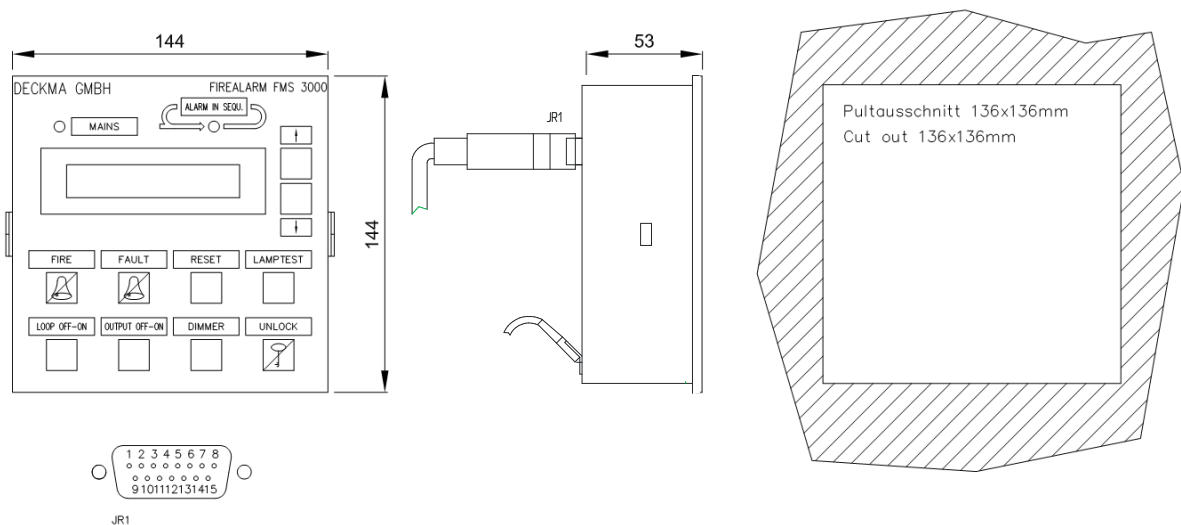

External dimensions: 144 x 144mm
 installation depth 53mm plus the corresponding D-SUB connector.

5.2. Switch cabinet installation

The switch cabinet, which houses the power supply, the main module, the power supply, the printer module, the VDR module, the fire loop module (FM), the output module and the accumulator, is usually installed inside the control console on the command bridge and connected to the operating panel with a plugged cable connection up to 3 m long.

The dimensions of the switch cabinet vary according to the number of modules being used. Please note in this case the specific dimensions of each module (see module descriptions).

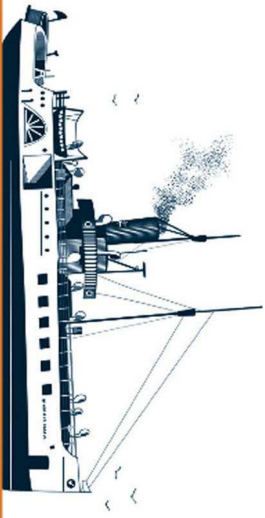

DECKMA GmbH

Decksmaschinen und Automation Vertriebs GmbH

Fon: +49 (0)4105 - 65 60-0 · Fax: +49 (0)4105 - 65 60-25 · Web: www.deckma-gmbh.de · E-Mail: info@deckma-gmbh.de

Technical documentation

2013091A

FMS3000

Typical assembly with up to 24 loops

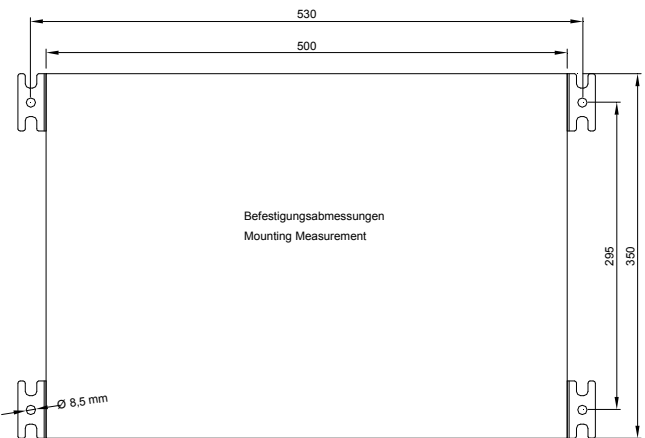

Material Stahlblech 1,5mm
Montageplatte Stahlblech 3mm
Lackierung Grau RAL 7035
Deckelbefestigung mittels 4 Schrauben M6

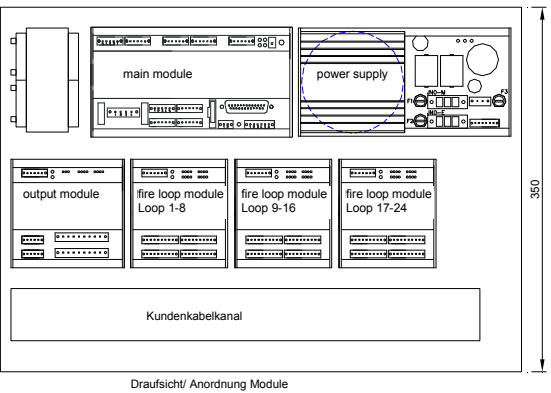
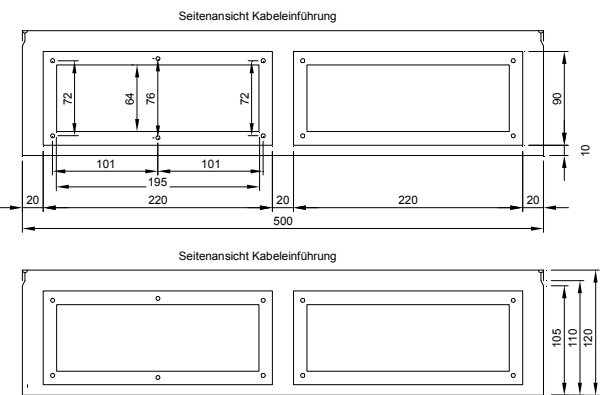
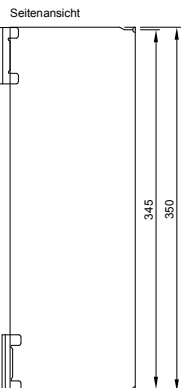

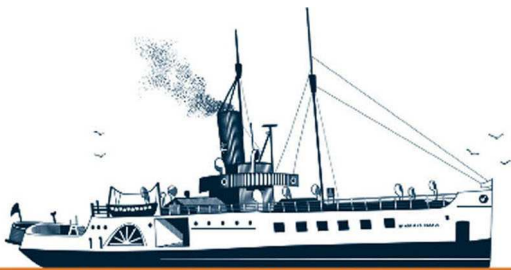

6. Configuration

In order to create the configuration, a pre-prepared Excel file is provided. The modules and their settings are then entered into the file and Excel creates the configuration file on the basis of these entries. The configuration file is copied onto an SD card, which is inserted into the data module.

In order to load this configuration file into the FMS, the data module is plugged into JR2 (main module) while it is switched off. When the FMS is switched on, the configuration file is automatically loaded. When the loading process has been completed, the FMS restarts. After a restart, the FMS must be switched off and the data module disconnected. The configuration procedure is then complete and the FMS can be started again.